

Subject: Lighting of Industrial/Commercial Developments Adjacent to Residential and Rural Properties (Exterior Lighting Impact Policy)

Policy No: 07-614
Approved by Council: January 12, 2004
Revised by Council: September 29, 2008
Replaces Old Policy No.:
Approved on:

1. Purpose

The Exterior Lighting Impact Policy establishes policy objectives, principles, techniques and implementation guidelines designed to minimize the impact of exterior lighting (from commercial/industrial developments) on nearby rural and residential properties. The Policy is also designed:

- 1.1 To recognize that “dark skies” are to be protected from light pollution wherever possible.
- 1.2 To recognize sustainability principles by ensuring that light energy is used wisely and efficiently in a manner not exceeding the amount required to accomplish the specific task at hand.
- 1.3 To ensure that commercial/industrial uses adjacent to rural/residential lands are developed on a “good neighbour” basis.
- 1.4 To recognize that exterior lighting should be designed so as to maintain adequate on-site safety and security in accordance with Crime Prevention through Environmental Design principles.
- 1.5 To recognize that excess lighting adversely impacts wildlife.

2. Background

- 2.1 Residents of both Langley and adjacent municipalities have expressed concerns to Council (at rezoning and development permit hearings) with respect to the impact of light trespass on their properties. Council has generally been sympathetic to these concerns and instructed staff to draft an “Exterior Lighting Impact Policy” for Council’s consideration. As the majority of concerns related to off-site lighting impacts have been in regard to commercial/industrial developments located adjacent to residential and rural properties, the “Exterior Impact Lighting Policy” is specifically directed towards addressing these conflicts.

3. Related Policy

- 3.1 The Exterior Lighting Impact Policy is in addition to the Township’s Business Searchlight Regulation Bylaw No. 3900 (as amended) which regulates the use of searchlights throughout the entire municipality.

4. Policy Objectives

The Exterior Lighting Impact Policy requires that the following techniques be used to reduce light trespass impacts on adjacent properties:

- 4.1 Limiting the hours of full illumination by turning off or dimming lights when not needed. All non-essential lighting is encouraged to be turned off after business hours or when not in use.
- 4.2 Sensor activated lighting is encouraged for security lighting.
- 4.3 Limiting off-site light trespass and glare by:
 - 4.3.1 using full cut-off fixtures designed so that no light shines above the bottom of the light fixture. Full cut-off fixtures should be a horizontally aligned flush mounted (non-protruding) lens. Sage or drop lenses are not permitted due to unnecessary glare.
 - 4.3.2 using back and/or side fitted light directing devices such as shields, visors or hoods to direct light distribution away from residential/rural property lines.
 - 4.3.3 using wall mounted light fixtures to illuminate doorways and pedestrian walkways immediately adjacent to buildings. Wall mounted light fixtures are to be fitted with full cut-off or other light direction devices designed to direct light downward.
 - 4.3.4 using ground oriented lighting to illuminate on-site sidewalks and pathways.
 - 4.3.5 using pole mounted fixtures to illuminate parking lots and outside storage, display and sales areas that are designed with a full cut-off fixture or alternatively being shielded. These fixtures may be:
 - located on a pole no higher than 20 feet from the ground
 - located on the outside perimeter of the lot being lit
 - directed downwards at 45 degrees away from adjacent rural or residential properties with a side-to-side horizontal aiming tolerance of no more than 22.5°.
 - being turned off or dimmed when full illumination is not necessary.
 - fixed at 90° to the pole when located anywhere other than the perimeter of the property.
 - 4.3.6 Examples of lighting fixtures designed to minimize the impact of exterior lighting on adjacent rural and residential properties are noted on Schedule "A" attached to this policy.
- 4.4 Lighting intended to “wash” buildings in a soft glow should only be located on sides of a building located away from adjacent rural/residential properties.

- 4.5 Lighting fixtures located under protective canopies are to be recessed or flush with the bottom surface of the structure, or alternatively be a surface mounted fixtures incorporating either a full cut-off design or shielding
- 4.6 Lighting on Signage shall be designed:
 - 4.6.1 to use constant illumination as opposed to flashing, intermittent or neon type lighting.
 - 4.6.2 to face illuminated sides of the signs away from adjacent rural/residential properties.
 - 4.6.3 to light only the sign and not be diffused to also light other site fixtures.
 - 4.6.4 to be turned off or dimmed when not needed.
 - 4.6.5 To comply otherwise with the Township's Sign Control Bylaw.

5. Implementation Policy:

- 5.1 The "Exterior Lighting Impact Policy" applies to all commercial/industrial developments located:
 - 5.1.1 immediately adjacent to a municipal boundary line with another municipality; or
 - 5.1.2 immediately adjacent to environmental areas including but not limited to riparian areas, ecological corridors and habitat patches; or
 - 5.1.3 within 150 metres of land zoned or designated for residential or rural purposes (R, RM, CD, RU and SR zones), except where rural or suburban zones are designated for future commercial/industrial purposes in the Township's O.C.P.
- 5.2 The scope of the Exterior Lighting Impact Policy applies to all forms of exterior lighting used to illuminate all external areas of a site including, but not limited to, the exterior lighting of buildings, canopies, surface parking areas, loading, storage, landscaping, signage and outdoor sales areas, as well as private roadways, walkways and access driveways. The policy does not apply to streetlights located on public roadways (which are regulated by Subdivision and Development Control and Traffic Bylaw standards).
- 5.3 All building and site development works and services that are subject to the provisions of Section 5.1, shall comply with the Township's "Exterior Lighting Impact Policy" requiring that the design of the "Exterior Lighting Impact Plan" be accepted by the Permits and Licences Department prior to a building permit being issued.
- 5.4 Proponents for developments subject to Policy Sections 5.1, 5.2 and 5.3 shall submit an Exterior Lighting Impact Plan as follows:
 - 5.4.1 Prepared by a qualified electrical engineer;

- 5.4.2 Indicating the location, type, intensity, direction, height, distances, proximity of neighbouring properties and other details such as glare control and other devices designed to lessen the impact of exterior commercial/industrial lighting and illuminated signage on nearby properties;
- 5.4.3 To include a stamped and sealed statement from a qualified electrical engineer certifying that the proposed Exterior Lighting Impact Plan conforms to this Policy;
- 5.4.4 The Exterior Lighting Impact Plan shall be reviewed by the Permits and Licences Department and must be acceptable to the Manager of Permits and Licences before a building permit may be issued;
- 5.4.5 The Manager of Permits and Licences may require that security be provided to guarantee the implementation of the Exterior Lighting Impact Plan; and
- 5.4.6 The building permit, when issued, shall be subject to the Exterior Lighting Impact Plan being satisfactorily implemented to the acceptance of the Manager of Permits and Licences prior to Final Inspection being granted. This, in most instances, will require the certification of a qualified electrical engineer that the lighting system has been installed in accordance with the accepted Exterior Lighting Impact Plan.

SCHEDULE "A"

FULL CUT-OFF POLE MOUNTED FIXTURE:

A full cut-off fixture with a flat lens emits no light above the horizontal plane of the fixture. Below are examples of full cut-off fixtures with a flat lens.

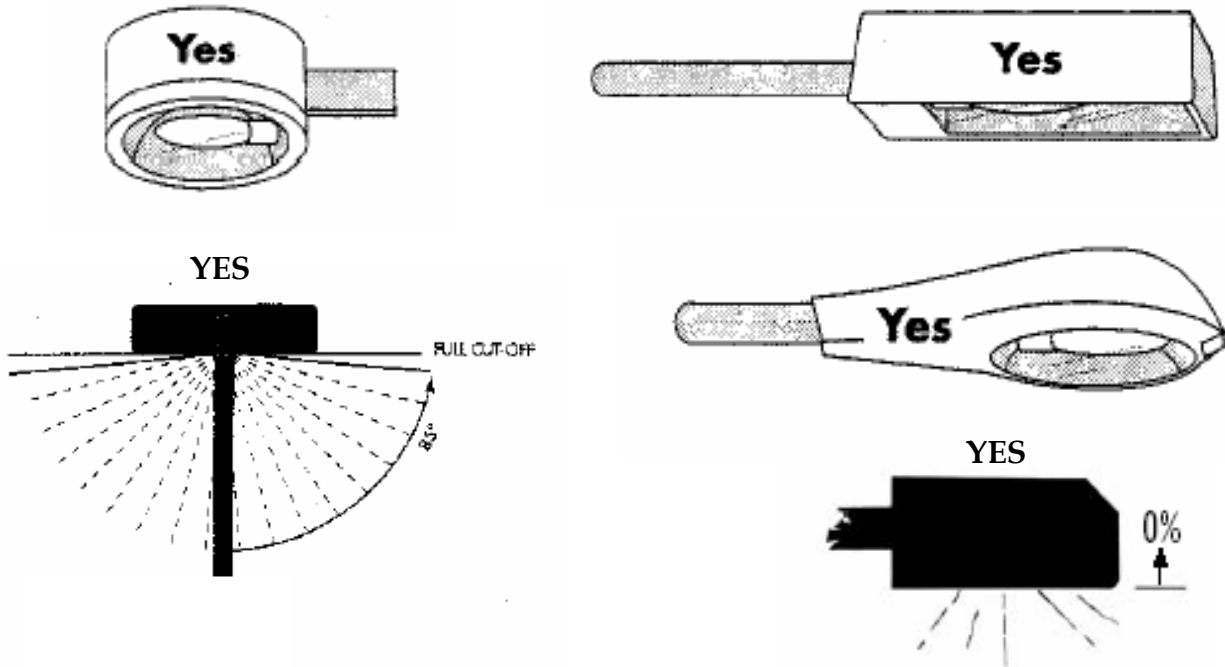

The same cut-off fixture may be directed downwards 45° for pole mounted fixtures located along the perimeter of a property with a side-to-side tolerance of no more than 22.5°. This allows for all light to be directed towards the subject site and away from rural/residential properties.

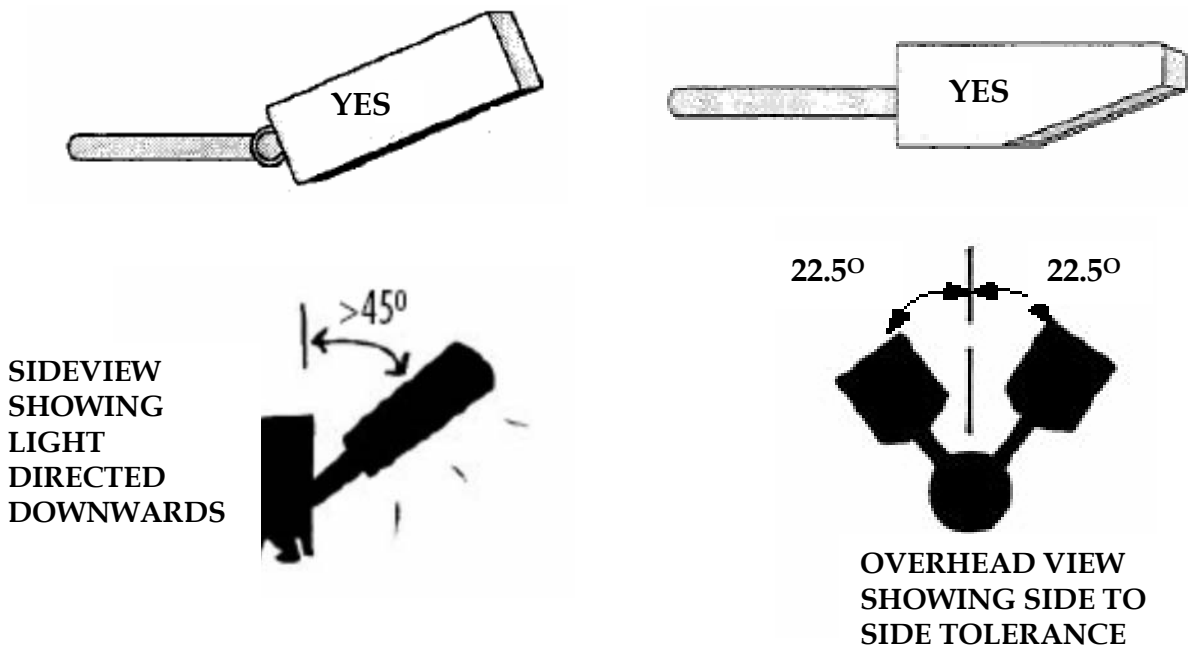

The full-cut off fixture should be equipped with a horizontally aligned lens. Sage or drop lenses are not permitted due to unnecessary glare. Below are three examples of sage or drop lenses.

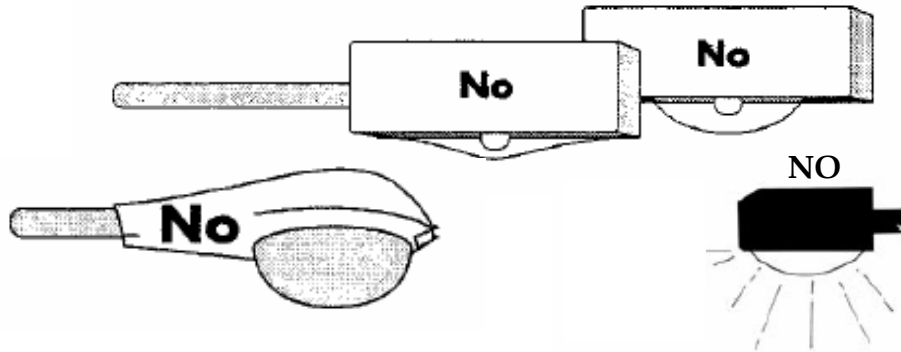

WALL MOUNTED FIXTURES:

All wall mounted fixtures should be a full cut-off fixture or alternatively equipped with a shielding devise.

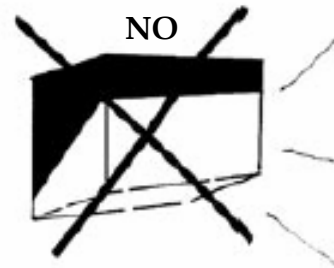
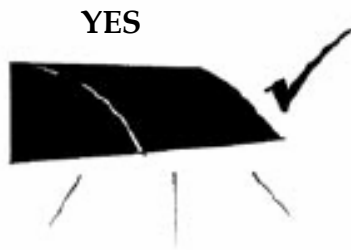

CANOPY LIGHTING:

All canopy lighting shall be recessed, flush mounted, or surface mounted given the fixture is full cut-off or shielded. All lenses shall be horizontally aligned.

